

Automatic Upper Arm Blood Pressure Monitor

M1 Basic (HEM-7121J-LAF) Instruction Manual



All for Healthcare

IM-HEM-7121J-LAF-EN-07-04/2023
3275342-0G

Table of Contents

- Introduction
- Important Safety Information
 1. Know Your Monitor
 2. Preparation
 3. Using Your Monitor
 4. Using Memory Function
 5. Other Settings
 6. Error Messages and Troubleshooting
 7. Maintenance
 8. Optional Medical Accessories
 9. Specifications
 10. Limited Warranty
 11. Guidance and Manufacturer's Declaration

Introduction

Thank you for purchasing the OMRON Automatic Upper Arm Blood Pressure Monitor. This blood pressure monitor uses the oscillometric method of blood pressure measurement. This means this monitor detects your blood movement through your brachial artery and converts the movements into a digital reading.

Safety Instructions

This instruction manual provides you with important information about the OMRON Automatic Upper Arm Blood Pressure Monitor. To ensure the safe and proper use of this monitor, READ and UNDERSTAND all of these instructions. If you do not understand these instructions or have any questions, contact your OMRON retail outlet or distributor before attempting to use this monitor. For specific information about your own blood pressure, consult with your physician.

Intended Use

This device is a digital monitor intended for use in measuring blood pressure and pulse rate in adult patient population. It is mainly designed for general household use.

Receiving and Inspection

Remove this monitor from the packaging and inspect for damage. If this monitor is damaged, DO NOT USE and consult with your OMRON retail outlet or distributor.

Important Safety Information

Read the Important Safety Information in this instruction manual before using this monitor. Follow this instruction manual thoroughly for your safety. Keep for future reference. For specific information about your own blood pressure, CONSULT WITH YOUR PHYSICIAN.

Warning Indicates a potentially hazardous situation which, if not avoided, could result in death or serious injury.

- DO NOT use this monitor on infants, toddlers, children or persons who cannot express themselves.
- DO NOT adjust medication based on readings from this blood pressure monitor. Take medication as prescribed by your physician. ONLY a physician is qualified to diagnose and treat high blood pressure.
- DO NOT use this monitor on an injured arm or an arm under medical treatment.
- DO NOT apply the arm cuff on your arm while on an intravenous drip or blood transfusion.
- DO NOT use this monitor in areas containing high frequency (HF) surgical equipment, magnetic resonance imaging (MRI) equipment, computerized tomography (CT) scanners. This may result in incorrect operation of the monitor and/or cause an inaccurate reading.
- DO NOT use this monitor in oxygen rich environments or near flammable gas.
- Consult with your physician before using this monitor if you have common arrhythmias such as atrial or ventricular premature beats or atrial fibrillation; arterial sclerosis; poor perfusion; diabetes; pregnancy; pre-eclampsia or renal disease. NOTE that any of these conditions in addition to patient motion, trembling, or shivering may affect the measurement reading.
- NEVER diagnose or treat yourself based on your readings. ALWAYS consult with your physician.
- To help avoid strangulation, keep the air tube and AC adapter cable away from infants, toddlers and children.
- This product contains small parts that may cause a choking hazard if swallowed by infants, toddlers and children.

AC Adapter (optional accessory) Handling and Usage

- DO NOT use the AC adapter if this monitor or the AC adapter cable is damaged. If this monitor or the cable is damaged, turn off the power and unplug the AC adapter immediately.
- Plug the AC adapter into the appropriate voltage outlet. DO NOT use in a multi-outlet plug.
- NEVER plug in or unplug the AC adapter from the electric outlet with wet hands.
- DO NOT disassemble or attempt to repair the AC adapter.

Battery Handling and Usage

- Keep batteries out of the reach of infants, toddlers and children.

Caution Indicates a potentially hazardous situation which, if not avoided, may result in minor or moderate injury to the user or patient, or cause damage to the equipment or other property.

- Stop using this monitor and consult with your physician if you experience skin irritation or discomfort.
- Consult with your physician before using this monitor on an arm where intravascular access or therapy, or an arteriovenous (A-V) shunt, is present because of temporary interference to blood flow and could result in injury.
- Consult with your physician before using this monitor if you have had a mastectomy or lymph node clearance.
- Consult with your physician before using this monitor if you have severe blood flow problems or blood disorders as cuff inflation can cause bruising.
- DO NOT take measurements more often than necessary because bruising, due to blood flow interference, may occur.
- ONLY inflate the arm cuff when it is applied on your upper arm.

- Remove the arm cuff if it does not start deflating during a measurement.
- DO NOT use this monitor for any purpose other than measuring blood pressure.
- During measurement, make sure that no mobile device or any other electrical device that emit electromagnetic fields is within 30 cm of this monitor. This may result in incorrect operation of the monitor and/or cause an inaccurate reading.
- DO NOT disassemble or attempt to repair this monitor or other components. This may cause an inaccurate reading.
- DO NOT use in a location where there is moisture or a risk of water splashing this monitor. This may damage this monitor.
- DO NOT use this monitor in a moving vehicle such as in a car or on an aircraft.
- DO NOT drop or subject this monitor to strong shocks or vibrations.
- DO NOT use this monitor in places with high or low humidity or high or low temperatures. Refer to section 9.
- During measurement, observe the arm to ensure that the monitor is not causing prolonged impairment to blood circulation.
- DO NOT use this monitor in high-use environments such as medical clinics or physician offices.
- DO NOT use this monitor with other medical electrical (ME) equipment simultaneously. This may result in incorrect operation and/or cause an inaccurate reading.
- Avoid bathing, drinking alcohol or caffeine, smoking, exercising and eating for at least 30 minutes before taking a measurement.
- Rest for at least 5 minutes before taking a measurement.
- Remove tight-fitting or thick clothing from your arm while taking a measurement.
- Remain still and DO NOT talk while taking a measurement.
- ONLY use the arm cuff on persons whose arm circumference is within the specified range of the cuff.
- Ensure that this monitor has acclimated to room temperature before taking a measurement. Taking a measurement after an extreme temperature change could lead to an inaccurate reading. OMRON recommends waiting for approximately 2 hours for the monitor to warm up or cool down when the monitor is used in an environment within the temperature specified as operating conditions after it is stored either at the maximum or at the minimum storage temperature. For additional information on operating and storage/ transport temperature, refer to section 9.
- DO NOT use this monitor after the durable period has ended. Refer to section 9.
- DO NOT crease the arm cuff or the air tube excessively.
- DO NOT fold or kink the air tube while taking a measurement. This may cause an injury by interrupting blood flow.
- To unplug the air plug, pull on the plastic air plug at the base of the tube, not the tube itself.
- ONLY use the AC adapter, arm cuff, batteries and accessories specified for this monitor. Use of unsupported AC adapters, arm cuffs and batteries may damage and/or may be hazardous to this monitor.
- ONLY use the approved arm cuff for this monitor. Use of other arm cuffs may result in incorrect readings.
- Inflating to a higher pressure than necessary may result in bruising of the arm where the cuff is applied. NOTE: refer to "If your systolic pressure is more than 210 mmHg" in section 3 for additional information.
- Read and follow the "Correct Disposal of This Product" in section 11 when disposing of the device and any used accessories or optional parts.

AC Adapter (optional accessory) Handling and Usage

- Fully insert the AC adapter into the outlet.
- When unplugging the AC adapter from the outlet, be sure to safely pull from the AC adapter. DO NOT pull from the AC adapter cable.
- When handling the AC adapter cable:
 - Do not damage it. / Do not break it. / Do not tamper with it.
 - DO NOT pinch it. / Do not forcibly bend or pull it. / Do not twist it.
 - DO NOT use it if it is gathered in a bundle.
 - DO NOT place it under heavy objects.
 - Wipe any dust off of the AC adapter.
 - Unplug the AC adapter when not in use.
 - Unplug the AC adapter before cleaning this monitor.

Battery Handling and Usage

- DO NOT insert batteries with their polarities incorrectly aligned.
- ONLY use 4 "AA" batteries with this monitor. DO NOT use other types of batteries. DO NOT use new and used batteries together. DO NOT use different brands of batteries together.
- Remove batteries if this monitor will not be used for a long period of time.
- If battery fluid should get in your eyes, immediately rinse with plenty of clean water. Consult with your physician immediately.
- If battery fluid should get on your skin, wash your skin immediately with plenty of clean, lukewarm water. If irritation, injury or pain persists, consult with your physician.
- DO NOT use batteries after their expiration date.
- Periodically check batteries to ensure they are in good working condition.

1. Know Your Monitor

1.1 Contents

Monitor, arm cuff, 4 "AA" batteries, instruction manual

1.2 Monitor

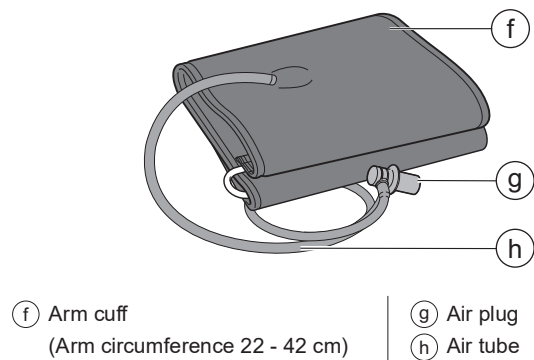
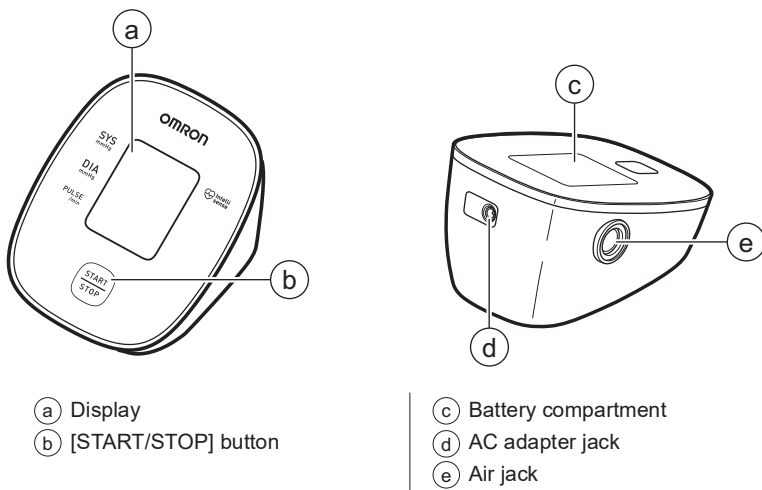

1.3 Display and Symbols

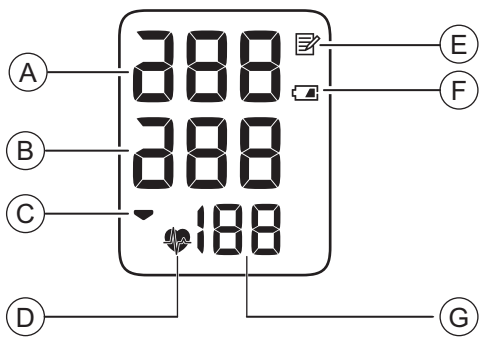

A	Systolic blood pressure reading
B	Diastolic blood pressure reading
C	Deflation symbol Appears during cuff deflation.
D	Heartbeat symbol Flashes during measurement.
E	Memory symbol Appears when viewing readings stored in the memory.
F	Low battery symbol Flashes when batteries are low.
	Depleted battery symbol Appears when batteries are depleted.
G	Pulse display Pulse rate appears after the measurement. When pressing the [Memory] button, the memory number appears for approximately one second before the pulse rate appears on the display.

1.4 Classification of BP (Blood Pressure)

2018 ESH/ESC* Guidelines for the management of arterial hypertension

Definitions of hypertension by office and home blood pressure levels

	Office	Home
Systolic Blood Pressure	≥ 140 mmHg	≥ 135 mmHg
Diastolic Blood Pressure	≥ 90 mmHg	≥ 85 mmHg

These ranges are from statistical values for blood pressure.

*European Society of Hypertension (ESH) and European Society of Cardiology (ESC).

Warning

- NEVER diagnose or treat yourself based on your readings. ALWAYS consult with your physician.

2. Preparation

2.1 Installing Batteries

1. Push down on the hook of the battery cover and pull downward.
2. Insert 4 "AA" batteries as indicated in the battery compartment.

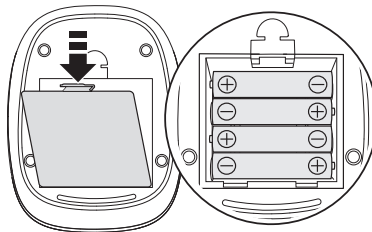

3. Close the battery cover.

Note

- When the " " symbol flashes on the display, it is recommended you replace batteries.
- To replace batteries, turn your monitor off and remove all batteries. Then replace with 4 new batteries at the same time.
- Replacing batteries will not delete previous readings.
- The supplied batteries may have a shorter life than new batteries.
- Disposal of used batteries should be carried out in accordance with local regulations.

2.2 Blood Pressure Measurement Tips

To help ensure an accurate reading, follow these directions:

- Stress raises blood pressure. Avoid taking measurements during stressful times.
- Measurements should be taken in a quiet place.
- It is important to take measurements at same times each day. Taking measurements in the morning and in the evening is recommended.
- Remember to have a record of your blood pressure and pulse readings for your physician. A single measurement does not provide an accurate indication of your true blood pressure. Please use the Blood Pressure Diary to keep records of several readings over a certain period of time. To download PDF files of the diary, visit www.omron-healthcare.com.

Caution

- Avoid bathing, drinking alcohol or caffeine, smoking, exercising and eating for at least 30 minutes before taking a measurement.
- Rest for at least 5 minutes before taking a measurement.

2.3 Applying the Arm Cuff

- The following steps are for applying the arm cuff to your left arm. When you take a measurement on your right arm, follow the cuff wrap instructions for a right arm use mentioned under "To take a measurement on your right arm" located at the end of this sub-section.
- The blood pressure can differ between the right arm and the left arm, and the measured blood pressure readings can be different. OMRON recommends to always use the same arm for measurement. If the readings between both arms differ substantially, check with your physician to determine as to which arm to use for your measurements.

Caution

- Remove tight-fitting or thick clothing from your arm while taking a measurement.

1. Plug the arm cuff into your monitor by inserting the air plug into the air jack securely until it clicks.

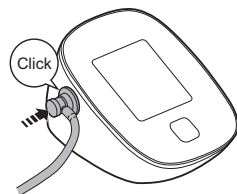

2. Place your hand through the cuff loop. Pull the cuff until it reaches your upper left arm.

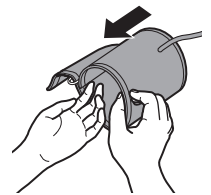

Note

- The bottom edge of the arm cuff should be 1 to 2 cm above the inside elbow. The air tube is on the inside of your arm and aligned with your middle finger.

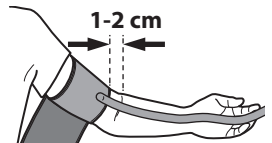

3. Make sure that the air tube is positioned on the inside of your arm and wrap the cuff securely, so it can not move around your arm.

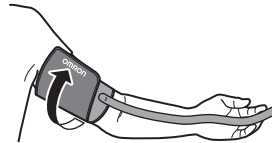

To take a measurement on your right arm

When you take a measurement on your right arm, the air tube should run along the side of your elbow, along the bottom of your arm. Be careful not to rest your arm on the air tube.



2.4 Sitting Correctly

To take a measurement, you need to be relaxed and comfortably seated in a room with a comfortable temperature.

Place your arm on the table.

- Sit in a comfortable chair with your back and arm supported.
- Keep your feet flat and your legs uncrossed.
- The arm cuff should be placed on your arm at the same level as your heart, with the arm resting comfortably on a table.

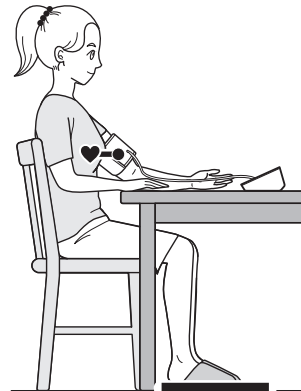

3. Using Your Monitor

3.1 Taking a Measurement

Caution

- DO NOT use this monitor with other medical electrical (ME) equipment simultaneously. This may result in incorrect operation and/or cause an inaccurate reading.
- Remain still and do not talk while taking a measurement.

1. Press the [START/STOP] button.

All symbols appear on the display before starting the measurement. The battery symbol that is displayed at this time do not indicate the battery level. They are displayed merely for confirmation.

2. Remain still and do not talk until the entire measurement process is complete.

The " " symbol flashes at every heartbeat.

After your monitor has detected your blood pressure and pulse rate, the cuff automatically deflates. Your blood pressure and pulse rate are displayed.

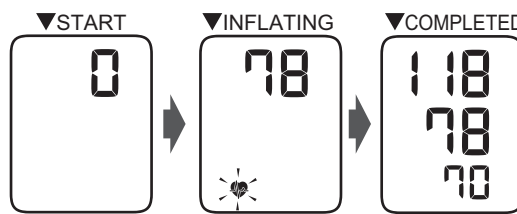

3. Press the [START/STOP] button to turn your monitor off.

Note

- Wait 2 - 3 minutes between measurements. The wait time allows the arteries to decompress and return to their pre-measurement state. You may need to increase the wait time depending on your individual physiological characteristics.

If your systolic pressure is more than 210 mmHg

If your systolic pressure is more than 210 mmHg, take a measurement manually. After the arm cuff starts to inflate, press and hold the [START/STOP] button until the monitor inflates 30 to 40 mmHg higher than your expected systolic pressure.

Note

- Do not inflate above 299 mmHg.

Caution

- Inflating to a higher pressure than necessary may result in bruising of the arm where the cuff is applied.

4. Using Memory Function

Your monitor automatically stores your last reading.

4.1 Viewing the Readings Stored in Memory

- Press and hold the [START/STOP] button for more than 5 seconds.
The last measurement value is displayed along with the memory symbol.

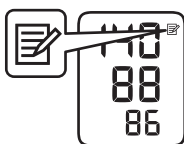

Note

- If there are no readings stored in the memory, the screen to the right is displayed.

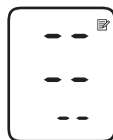

- Press the [START/STOP] button to turn off your monitor.

Note

- Your monitor will automatically turn off after 2 minutes.

5. Other Settings

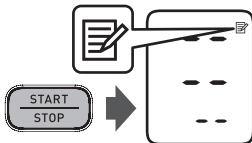

5.1 Deleting Reading Stored in Memory

- Press and hold the [START/STOP] button for more than 15 seconds.
The screen to the right is displayed and the reading is deleted.



6. Error Messages and Troubleshooting

In case of any of the below problems occur during measurement, first check that no other electrical device is within 30 cm. If the problem persists, please refer to the table below.

Display/Problem	Possible Cause	Solution
E1 appears or the arm cuff does not inflate.	The [START/STOP] button was pressed while the arm cuff is not applied. Air plug is not completely plugged into the monitor. The arm cuff is not applied correctly. Air is leaking from the arm cuff.	Press the [START/ STOP] button again to turn the monitor off. After inserting the air plug securely and applying the arm cuff correctly, press the [START/STOP] button. Insert the air plug securely. Refer to sub-section 2.3. Apply the arm cuff correctly, then take another measurement. Refer to sub-section 2.3. Replace the arm cuff with a new one. Contact your OMRON retail outlet or distributor.
E2 appears or a measurement cannot be complete after the arm cuff inflates.	You move or talk during a measurement and the arm cuff does not inflate sufficiently. The systolic pressure is above 210 mmHg and a measurement cannot be taken.	Remain still and do not talk during a measurement. If "E2" appears repeatedly, inflate the arm cuff manually until the systolic pressure is 30 to 40 mmHg above your previous readings. Refer to sub-section 3.1. Inflate the arm cuff manually until the systolic pressure is 30 to 40 mmHg above your previous readings. Refer to sub-section 3.1.
E3 appears	The arm cuff is inflated exceeding the maximum allowable pressure.	Do not touch the arm cuff and/or bend the air tube while taking a measurement. If inflating the arm cuff manually, refer to the end of sub-section 3.1.
E4 appears	You move or talk during a measurement. Vibrations disrupt a measurement.	Remain still and do not talk during a measurement.
E5 appears does not flash during a measurement	The pulse rate is not detected correctly.	Apply the arm cuff correctly, then take another measurement. Refer to sub-section 2.3. Remain still and sit correctly during a measurement.
Er appears	The monitor has malfunctioned.	Press the [START/ STOP] button again. If "Er" still appears, contact your OMRON retail outlet or distributor.
 flashes	Batteries are low.	Replacing all 4 batteries with new ones is recommended. Refer to sub-section 2.1.
 appears or the monitor is turned off unexpectedly during a measurement.	Batteries are depleted.	Immediately replace all 4 batteries with new ones. Refer to sub-section 2.1.
Nothing appears on the display of the monitor.	Battery polarities are not properly aligned.	Check the battery installation for proper placement. Refer to sub-section 2.1.

Display/Problem	Possible Cause	Solution
Readings appear too high or too low.	Blood pressure varies constantly. Many factors including stress, time of day, and/or how you apply the arm cuff, may affect your blood pressure. Review sub-sections 2.2 - 2.4 and section 3.	
Any other problems occur.	Press the [START/STOP] button to turn the monitor off, then press it again to take a measurement. If the problem continues, remove all batteries and wait for 30 seconds. Then re-install batteries. If the problem still persists, contact your OMRON retail outlet or distributor.	

7. Maintenance

7.1 Maintenance

- To protect your monitor from damage, please follow the directions below:
- Changes or modifications not approved by the manufacturer will void the user warranty.

⚠ Caution

- DO NOT disassemble or attempt to repair this monitor or other components. This may cause an inaccurate reading.

7.2 Storage

Store your monitor in a clean, safe location.
Do not store your monitor:

- If your monitor is wet.
- In locations exposed to extreme temperatures, humidity, direct sunlight, dust or corrosive vapors such as bleach.
- In locations exposed to vibrations or shocks.

7.3 Cleaning

- Do not use any abrasive or volatile cleaners.
- Use a soft dry cloth or a soft cloth moistened with mild (neutral) detergent to clean your monitor and arm cuff, and then wipe them with a dry cloth.
- Do not wash or immerse your monitor and arm cuff or other components in water.
- Do not use gasoline, thinners or similar solvents to clean your monitor and arm cuff or other components.

7.4 Calibration and Service

- The accuracy of this blood pressure monitor has been carefully tested and is designed for a long service life.
- It is generally recommended to have the unit inspected every two years to ensure correct functioning and accuracy. Please consult your authorised OMRON dealer or the OMRON Customer Service at the address given on the packaging or attached literature.

8. Optional Medical Accessories

Small arm cuff
Arm circumference
17 - 22 cm

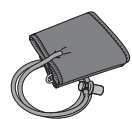

(HEM-CS24)

Arm cuff
Arm circumference
22 - 42 cm



(HEM-RML31)

Note

- Do not throw the air plug away. The air plug can be applicable to the optional cuff.

AC Adapter

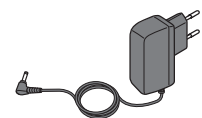

(HHP-CM01)



(HHP-BFH01)

For further information, visit our website at www.omron-healthcare.com

Using the AC Adapter (optional accessory)

Note

- Make sure not to place your monitor in a location where it is difficult to plug and unplug the AC adapter.
- We recommend keeping batteries in your monitor at all times, even if you choose to use the AC adapter. If only the AC adapter is used without keeping batteries in your monitor, you may need to reset the date and time each time you unplug and plug back the AC adapter. The readings will not be deleted.

- Insert the AC adapter plug into the AC adapter jack on the rear side of your monitor.

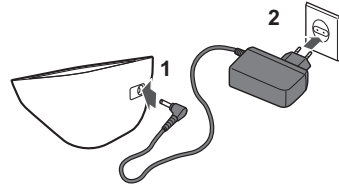

- Plug the AC adapter into an electrical outlet.

To unplug the AC adapter, unplug the AC adapter from the electrical outlet and then remove the AC adapter plug from the monitor.

⚠ Caution

- ONLY use the AC adapter, arm cuff, batteries and accessories specified for this monitor. Use of unsupported AC adapters, arm cuffs and batteries may damage and/or may be hazardous to this monitor.

9. Specifications

Product description	Automatic Upper Arm Blood Pressure Monitor
Product category	Electronic Sphygmomanometers
Model (code)	M1 Basic (HEM-7121J-LAF)
Display	LCD digital display
Cuff pressure range	0 to 299 mmHg
Blood pressure measurement range	20 to 280 mmHg
Pulse measurement range	40 to 180 beats / min.
Accuracy	Pressure: ±3 mmHg Pulse: ±5% of display reading
Inflation	Automatic by electric pump
Deflation	Automatic pressure release valve
Measurement method	Oscillometric method
Operation mode	Continuous operation
IP classification	Monitor: IP20 / Optional AC adapter: IP21 (HHP-CM01) or IP22 (HHP-BFH01)
Rating	DC6 V 4.0 W
Applied part	Type BF (arm cuff)
Power source	4 "AA" batteries 1.5 V or optional AC adapter (INPUT AC 100 - 240 V 50 - 60 Hz 0.12 - 0.065 A)
Battery life	Approximately 1000 measurements (using new alkaline batteries)
Durable period (Service life)	Monitor: 5 years / Cuff: 5 years / Optional AC adapter: 5 years
Operating conditions	+10°C to +40°C / 15 to 90% RH (non-condensing) / 800 to 1060 hPa
Storage / Transport conditions	-20°C to +60°C / 10 to 90% RH (non-condensing)
Weight	Monitor: approximately 250 g (not including batteries) / Arm cuff: approximately 170 g
Dimensions (approximately value)	Monitor: 108 mm (W) × 83 mm (H) × 140 mm (L) Arm cuff: 145 mm × 594 mm (air tube: 750 mm)
Cuff circumference applicable to the monitor	170 to 420 mm (included arm cuff: (220 to 420 mm))
Memory	Last measurement
Contents	Monitor, arm cuff (HEM-RML31), 4 "AA" batteries, Instruction Manual
Protection against electric shock	Internally powered ME equipment (when using only batteries) Class II ME equipment (optional AC adapter)
Maximum temperature of the applied part	Lower than 48 °C

Note

- These specifications are subject to change without notice.
- This monitor is clinically investigated according to the requirements of EN ISO 81060-2:2014 and complies with EN ISO 81060-2:2014 and EN ISO 81060-2:2019+A1:2020. (excluding pregnant and pre-eclampsia patients). In the clinical validation study, K5 was used on 85 subjects for determination of diastolic blood pressure.
- IP classification is degrees of protection provided by enclosures in accordance with IEC 60529. This monitor and optional AC adapter are protected against solid foreign objects of 12.5 mm diameter and greater such as a finger. The optional AC adapter HHP-CM01 is protected against vertically falling water drops which may cause issues during a normal operation. The optional AC adapter HHP-BFH01 is protected against oblique falling water drops which may cause issues during a normal operation.
- Operating mode is classification in accordance with IEC 60601-1.

10. Limited Warranty

Thank you for buying an OMRON product. This product is constructed of high quality materials and great care has been taken in its manufacturing. It is designed to give you every satisfaction, provided that it is properly operated and maintained as described in the instruction manual.

This product is warranted by OMRON for a period of 5 years after the date of purchase. The proper construction, workmanship and materials of this product is warranted by OMRON. During this period of warranty OMRON will, without charge for labour or parts, repair or replace the defect product or any defective parts.

The warranty does not cover any of the following:

- Transport costs and risks of transport.
- Costs for repairs and / or defects resulting from repairs done by unauthorised persons.
- Periodic check-ups and maintenance.
- Failure or wear of optional parts or other attachments other than the main device itself, unless explicitly warranted above.
- Costs arising due to non-acceptance of a claim (those will be charged for).
- Damages of any kind including personal caused accidentally or from misuse.
- Calibration service is not included within the warranty.
- Optional parts have a one (1) year warranty from date of purchase. Optional parts include, but are not limited to the following items: cuff and cuff tube.

Should warranty service be required please apply to the dealer whom the product was purchased from or an authorised OMRON distributor. For the address refer to the product packaging / literature or to your specialised retailer. If you have difficulties in finding OMRON customer services, contact us for information: www.omron-healthcare.com



Repair or replacement under the warranty does not give rise to any extension or renewal of the warranty period.

























The warranty will be granted only if the complete product is returned together with the original invoice / cash ticket issued to the consumer by the retailer.

11. Guidance and Manufacturer's Declaration

CE0197 UKCA0086

- This blood pressure monitor is designed according to the European Standard EN1060, Non-invasive sphygmomanometers Part 1: General Requirements and Part 3: Supplementary requirements for electromechanical blood pressure measuring systems.
- This OMRON product is produced under the strict quality system of OMRON HEALTHCARE Co., Ltd., Japan. The Core component for OMRON blood pressure monitors, which is the Pressure Sensor, is produced in Japan.
- Please report to the manufacturer and the competent authority of the Member State in which you are established about any serious incident that has occurred in relation to this device.

Symbols description	
	Applied part - Type BF Degree of protection against electric shock (leakage current)
	Class II equipment. Protection against electric shock
IP XX	Ingress protection degree provided by IEC 60529

Symbols description	
	CE Marking
	UKCA Marking
	Serial number
	LOT number
	Unique device identifier
	Medical Device
	Temperature limitation
	Humidity limitation
	Atmospheric pressure limitation
	Indication of connector polarity
	For indoor use only
	OMRON's trademarked technology for blood pressure measurement
	Identifier of cuffs compatible for the device
	Cuff positioning indicator for the left arm
	Marker on the cuff to be positioned above the artery
	Range pointer and brachial artery alignment position
	QUALITY PASS Manufacturer's quality control mark
LATEX FREE	Not made with natural rubber latex
	Range indicator of arm circumferences to help selection of the correct cuff size.
	Arm circumference
	Need for the user to consult this instruction manual.
	Need for the user to follow this instruction manual thoroughly for your safety.
	Direct current
	Alternating current
	Date of manufacture

Important information regarding Electromagnetic Compatibility (EMC)

HEM-7121J-LAF conforms to EN60601-1-2:2015 Electromagnetic Compatibility (EMC) standard. Further documentation in accordance with this EMC standard is available at www.omron-healthcare.com. Refer to the EMC information for HEM-7121J-LAF on the website.



Correct Disposal of This Product (Waste Electrical & Electronic Equipment)

This marking shown on the product or its literature, indicates that it should not be disposed of, with other household wastes at the end of its working life. To prevent possible harm to the environment or human health from uncontrolled waste disposal, please separate this product from other types of wastes and recycle it responsibly to promote the sustainable reuse of material resources.



Household users should contact either the retailer where they purchased this product, or their local government office, for details of where and how they can return this item for environmentally safe recycling.

Business users should contact their supplier and check the terms and conditions of the purchase contract. This product should not be mixed with other commercial waste for disposal.

Manufacturer 	OMRON HEALTHCARE Co., Ltd. 53, Kunotsubo, Terado-cho, Muko, KYOTO, 617-0002 JAPAN
EU-representative 	OMRON HEALTHCARE EUROPE B.V. Scorpius 33, 2132 LR Hoofddorp, THE NETHERLANDS www.omron-healthcare.com
Importer in EU	OMRON HEALTHCARE MANUFACTURING VIETNAM CO., LTD. No.28 VSIP II, Street 2, Vietnam-Singapore Industrial Park II, Binh Duong Industry-Services-Urban Complex, Hoa Phu Ward, Thu Dau Mot City, Binh Duong Province, Vietnam
Subsidiaries	OMRON HEALTHCARE UK LTD. Opal Drive, Fox Milne, Milton Keynes, MK15 0DG, UK www.omron-healthcare.com/distributors OMRON SANTÉ FRANCE SAS www.omron-healthcare.com/distributors